

DEFINITION OF TERMS

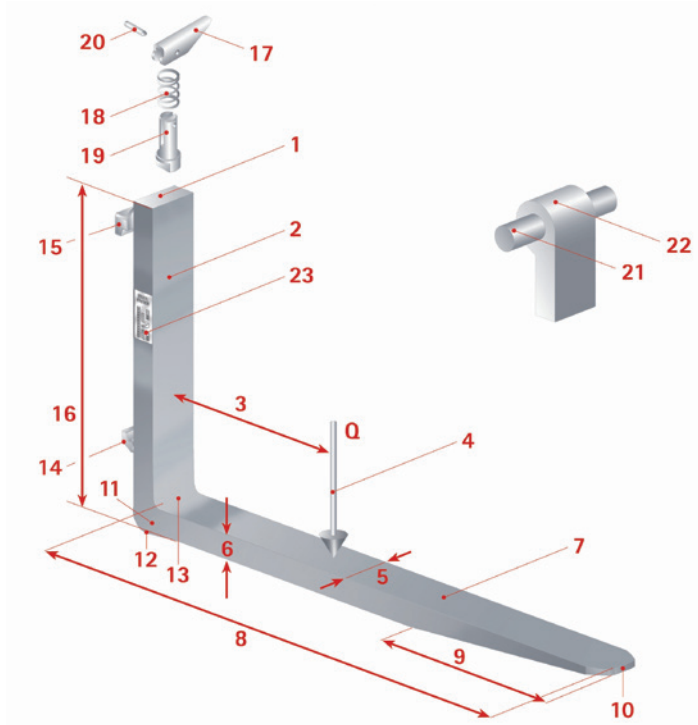

- 1 Fork head
- 2 Back / shank
- 3 Load center (LC)
- 4 Load (Q)
- 5 Fork width (GB)
- 6 Fork thickness (GD)
- 5 x 6 Cross-section (width x thickness)
- 7 Fork blade
- 8 Blade length (L)
(measurement from inner side of back to the tip)
- 9 Taper
- 10 Fork tip
- 11 Heel
- 12 Wear zone
- 13 Inner heel
- 14 Lower hook
- 15 Upper hook
- 14 + 15 Suspension
- 16 Backheight (RH)
- 17 Lever
- 18 Spring
- 19 Bolt
- 20 Pin
- 17 - 20 Locking device / positioning lock
- 21 Shaft
- 22 Eye / tube
- 23 Marking / stamping

STAMPING

ISO 2330 requires the permanent marking of forks. Such marking is important e.g. in order to identify forks. Any fork without marking should be replaced.

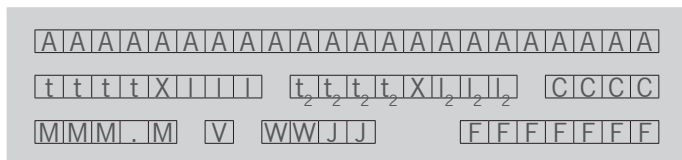

- A: Article number (optional)
- t: Rated capacity per piece in kg
- l: Load center (LC)
- M: Material
- V: Manufacturer's logo / sign
- W: Week of production
- J: Year of production
- C: Material code
- F: No. of production order

Technical information will not be up-dated automatically.